

Show 1709-1 Side to Side Sweater



Directions are for size X-Small/ Small. Changes for size Medium/Large are in parentheses.

MODA DEA® “Fashionista™”, Art. R157 (3.5 ounce/183 yard balls): 3(4) balls No.6121 Cornsilk or 6131 Boysenberry.

Knitting Needles: 5mm [US 8]
Stitch Markers, Cablestitch holder, yarn needle

GAUGE: 16 sts = 4”; 23 rows = 4” in St st.
CHECK YOUR GAUGE. Use any size needle to obtain the gauge given.

To Fit Chest: 28-34(36-42)”
Finished Schematic Measurements are of unstretched garment.

SPECIAL ABBREVIATIONS:

C2F: Sl 1 st to cablestitch holder and hold in Front, K next st, K st from holder.

M1: Insert the right-hand needle from front to back under the horizontal strand that runs between the stitches on the right- and left-hand needles and move st to left hand needle. Knit the new stitch from back

Cable Pattern (over 2 sts):

Row 1(RS): C2F

Row 2 (WS): Purl

LEFT FRONT (begins with tie): Cast on 10 sts.

Row 1: Sl 1 knitwise; [K1, P1] 4 times, K1, turn. Rep Row 1 until piece measures 16 (25)” from beg.

Next row: Sl 1 knitwise; M1, work rib to last st, M1, K1 – 12sts.

Next 5 rows: Sl 1 knitwise; [P1, K1] 5 times, K1, turn.

Last tie row: Sl 1 knitwise; [P1, K1] 2 times. M1, [P1, K1] 3 times, K1, turn – 13 sts

Body:

Row 1(RS): Continue working the first 6 sts in rib pat, place marker, M1, place marker, continue working the last 7 sts in rib pat - 14 sts.

Row 2: Work 7 rib sts, K new st, work 6 rib sts.

Note: Continuing to work rib sts the same as row 1 and 2, slipping first st of each row; work between markers as follows:

Row 3: P new st, work to marker, M1 – 2 sts.

Row 4: K new st, work to marker, M1 – 3 sts.

Row 5: P to marker, M1 – 4 sts.

Row 6: K to marker, M1 – 5 sts.

Row 7: P to marker, M1 – 6 sts.

Row 8: K new st, P5, M1 – 7 sts.

Row 9: K new st, P5, K1, M1 – 8 sts.

Row 10: P2, K5, P1, M1 – 9 sts.

Row 11: C2F, P5, C2F, M1 – 10 sts

Row 12: K1, P2, K5, P2, M1 – 11 sts.

Pat is now established. Cont to inc 1 st on end of each row before 2nd marker, working new sts in pat. (5 sts Rev st st, 2 st cable pat,) until 73 (87) sts between markers – 86 (100) sts total.

Shape side:

Row 1: With RS facing, BO 14 (17) work across in pat **without** any increases – 72 (83) sts.

Row 2 AND EVERY WRONG SIDE ROW: Work in pat .

Row 3, 5, 7, 9, 11, 13, 15 (17): BO 4 at beg of row, pat across rem sts – 44 (51) sts.

Shape Armhole:

Row 1: With RS facing, BO 8 sts. - 36 (43) sts.

Row 2 AND EVERY WRONG SIDE ROW: Work in pat as set

Row 3, 5, 7, 9, 11, 13, (15, 17, 19): BO 2 sts at beg of each row – 24 (25) sts.

Shape Shoulder: RS facing, bind off 16 (17) sts; for neckband work the last 7 sts in P1/ K1 rib for 2 (2.25)". Bind off.

RIGHT FRONT: Work beg of tie same as Left Front to 16(25)”

Next row: Sl 1 knitwise; M1, work rib to last st, M1, K1 – 12 sts.

Next 5 rows: Sl 1 knitwise; [P1, K1] 5 times, K1, turn.

Last tie row: Sl 1 knitwise; [P1, K1] 3 times; M1, [P1, K1] 2 times, K1, turn – 13 sts.

Body:

Row 1 (RS): Continue working the first 7 sts in rib pat, place marker, M1, place marker, work last 6 sts in rib pat. – 14 sts.

Row 2: Work 6 rib sts, K new st, work 7 rib sts.

Note: Continuing to work rib sts the same as row 1 and 2, slipping first st of each row; work between markers as follows:

Row 3: P new st, work to marker, M1 – 2 sts.

Row 4: K new st, work to marker, M1 – 3 sts.

Row 5: P to marker, M1 – 4 sts.

Row 6: K to marker, M1 – 5 sts.

Row 7: P to marker, M1 – 6 sts.

Row 8: K new st, P5, M1 – 7 sts.

Row 9: K new st, P5, K1, M1 – 8 sts.

Row 10: P2, K5, P1, M1 – 9 sts.

Row 11: C2F, P5, C2F, M1 – 10 sts

Row 12: K1, P2, K5, P2, M1 – 11 sts.

Pat is now established. Cont to inc 1 st on end of each row before 2nd marker, working new sts in pat. (5 sts rev st, 2 st cable pat) until 73 (87) sts between markers – 86 (100) sts total.

Shape Side:

Row 1: With WS facing, BO 14 (17) cont working in pat **without** any increases – 72 (83) sts.

Row 2 AND EVERY RIGHT SIDE ROW: Work in pat .

Row 3, 5, 7, 9, 11, 13, 15 (17): BO 4 at beg of row, work across rem sts – 44 (51) sts.

Shape Armhole:

Row 1: With WS facing, BO 8 sts. - 36 (43) sts.

Row 2 AND EVERY RIGHT SIDE ROW: Work in pat.

Row 3, 5, 7, 9, 11, 13, (15, 17, 19): BO 2 sts at beg of each row – 24 (25) sts.

Shape Shoulder: WS facing, bind off 16 (17) sts; for neckband work the last 7 sts in P1/ K1 rib for 2 (2.25) inches. Bind off.

BACK: Cast on 73 (87) sts.

Row 1-6: Work in P1, K1 rib.

Row 7 (WS): K4, [P2, K5] 9 (11) times, P2, K4.

Row 8: P4, [C2F, P5] 9 (11) times, C2F, P4.

Rep last 2 rows until piece measures 9(11)” from beg.

Shape Armholes and Shoulders:

BO 3 sts at beg of next 2 rows – 67 (81) sts

BO 2 sts at beg of next 2 rows – 63 (77) sts

BO 1 st at beg of next 2 (4) rows – 61 (73) sts.

Work even until 16.5(19.5) “ from beg. Bind off.

SLEEVES: Cast on 50 (57) sts.

Row 1-5: Work in P1, K1 ribbing.

Row 6-9 (6-11): Work in Rev st st (P on rs, K on ws)

Shape Armholes: Continuing in Rev st st work as follows:

Row 1-2: Bind off 2 sts at beg of next 2 rows – 46 (53) sts.

Row 3-6: Dec 1 st at beg of row - 42 (49) sts.

Row 7-8: Work across

Row 9-10: Bind off 1 st at beg of row – 40 (47) sts.

Rep last 4 rows 4 (5) more times – 32 (37) sts.

BO 1 at beg next 2 (6) rows – 30 (31) sts.

BO 2 beg of next 2 rows – 26 (29)

BO 3 beg of next 2 rows – 20 (21)

BO last 20 (21) sts.

FINISHING: Sew shoulder and sleeve seams. Set in sleeves. Sew side seams. Sew ends of neckband together and sew to bound off sts of back neck. Weave in all ends

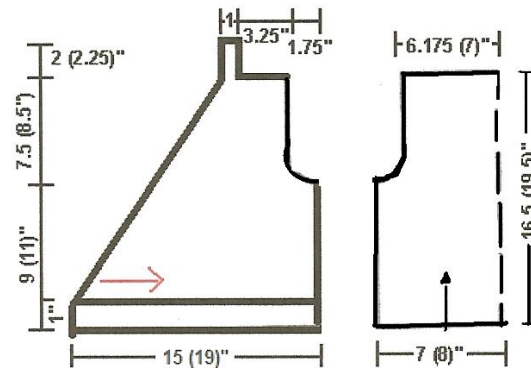

*Designed by Lisa Gentry
For Coats & Clark*

ABBREVIATIONS: **approx** = approximately; **beg** = begin(ning); **BO** = bind off; **inc** = increase(s)(d)(ing); **K** = knit; **mm** = millimeters; **P** = Purl; **pat(s)** = pattern(s); **rem** = remaining; **rep** = repeat; **Rev st st** = Reverse stockinette stitch; **rs** = right side; **rnd(s)** = round(s); **sl** = slip; **sl st** = slip stitch; **st(s)** = stitch(es); **St st** = Stockinette stitch; **ws** = wrong side; [] = work directions in brackets the number of times specified; * or ** = repeat whatever follows the * or ** as indicated.

©2006 COATS & CLARK Inc, Greer, SC, 29650
www.coatsandclark.com www.modadea.com